

Smart Waste Management System using Internet of Things and RFID Technology

Vasundhra Chaturvedi, Mukesh Yadav, Nidhi Tiwari

Department of Electronics and Communication Engineering, Sagar Institute of Research & Technology, SAGE University, Indore, Madhya Pradesh, India

Corresponding author: Vasundhra Chaturvedi, Email: vasundharav96@gmail.com

More recently the government's massive fundraising campaign has been working to separate the garbage. The Indian government has invested a lot of money and energy in this work. To separate the garbage the government also needs sophisticated high-energy equipment. These machines also required maintenance costs from time to time. Health illness also affects when manual workers. The government also works to raise awareness of the separation of dry and wet waste through campaigns, banners, posters and celebrity campaigns. To overcome and alleviate the above problem our smart garbage dissection program will educate and name the user to make the best use of the dustbin. A micro-controller, sensors, servo motors, DC motor, RFID and Wi-Fi technology that will be used to build this great garbage disposal system. The main purpose of this paper is to educate and reward the various users who dump garbage on a daily basis. This program will have an RFID learning module that can monitor user identification with the RFID tag and the Wi-Fi system will send user data to an IOT-enabled application. At this point the IOT app user can check their bonus points. This bonus point can be adjusted for another discount offer.

Keywords: IOT, Automatic Segregator, RFID, Waste Management, MCU.

1 Introduction

This paper research on the many ways that have been developed in different cities to combat the increasing waste generated. Burning, waste disposal is being done on a large scale in all countries. Waste disposal before treatment, it will be very useful and will save money and the environment. Basically waste is to be packaged as plastic once non-plastic because all types of plastic do not decomposed and some waste often decomposes easily. Hence daily waste can be separated. This smart drum uses Internet of Things (IoT) and segmentation sensors as a means of separating waste. The Internet of Things (IoT) is defined as the concept around it organizations are connected via wireless and wireless user-friendly settings. A different situation management system is well done to prevent the dumping of garbage in bins. When the bins are full, a notice is sent to the local garbage collector requesting garbage collection. In this technology we use different sensors and a servo motor, wi-fi module gets data from different sensors and RFID tag [1].

Many days, garbage is left untreated and neglected for a long time. These include residual waste from Publics, industries etc. in today's age of technology-driven society, we need to use the system to change the process of cleaning garbage. Continuing with automation process, we propose and use garbage bins designed to help us technically. These smart segregator can be used on a large scale with the file Traditional dust bins can be removed to protect the waste from roads. The level of waste in bins can be easily monitored and maintained from time to time. The idea of using this to avoid pollution is also dangerous garbage production [2],[3].

The system uses intelligent technology with the help of different sensors placed to continuously detect the waste placed inside bins. Different types of sensors like metal sensor, dry sensor, wet sensor and IR sensor are used with unique wi-fi controller which is node MCU controller and servo motor which is being used to separate different types of waste and which is further displayed on IoT based application on blink app we also use RFID tag for user identification for segregation process. With the increase in population each year, the amount of waste produced increases significantly. This has led to many serious problems. Garbage collection in large areas of the world leads to the construction of landfills with dangerous consequences. The smell of rotten rubbish pollutes the environment by giving off a foul odor. Disposal of waste in water bodies pollutes the entire oceans and the interconnected sea which affects the quality of drinking water and the health of aquatic animals. Toxic gases are released into the air and the whole environment is affected. Waste management is therefore a very serious problem in modern times. If the waste produced is effectively managed at the source level, many things can be converted and restricted. Separation of waste into wet, dry and metal phases can help to dispose of waste properly and to implement the principle of recycling, mitigation and recycling. Wet waste can rot to produce plant manure, metal waste and dry waste can be recycled. So Automatic Segregator we have many applications in waste management. The system separates waste into three separate bins under a wet, dry and metal section. Various sensors are used to determine the type of waste. The level of waste in the bins is monitored continuously so that the bins do not overflow and dispose of in a timely manner. Notice is sent to the relevant authorities about the location of the bin [3].

In many parts of India, garbage is dumped as one, mixing fine and indestructible waste, causing the spread of many epidemics. In our daily lives, we see the bins are overflowing and all the waste is spilled which leads to pollution. Because of population growth, industrialization, and economic growth, trends, important increase in the generation of Solid Waste Municipalities (MSW) has written all over the world our Swachh Bharath Scheme Honorable Prime Minister to make India clean and green, this automatic waste filter bin is a step-by-step we have made it commendable. While the barrels are there too waste-separating prototypes, none of which are used domestic and industrial areas. Our system simply separate metal and non-metallic and other waste so in this paper, smart automated trash bin

prototype is used with active waste segmentation is closed and avoids unnecessary the spread of germs.

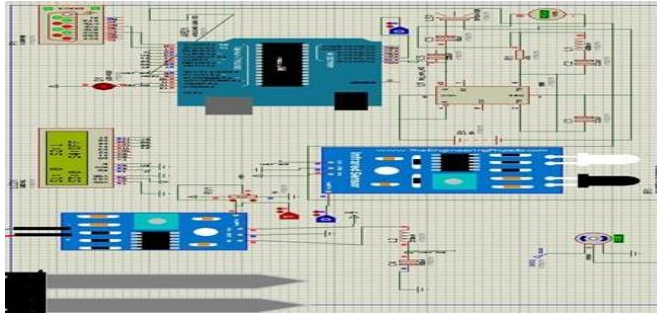

Fig. 1. System architecture

2 System Architecture

- First we use different types of sensors wi-fi controller get data from different sensors like IF sensor, metal sensor, dry sensor and wet sensor when waste is put and lands on moisture sensor depending upon threshold set waste are classified as dry or wet [4].
- Servo motor kept waste into different bins it classifies waste depending on sensors and collects waste and put it into separate bins it rotate at different precision. Runs to either direction depending upon the type of waste and the waste goes in appropriate compartment
- We also use LCD which is 16*2 LCD with 12C module it will reduce number of wire used in LCD interface [5].
- Controller we used is Node MCU controller and data is being represented on IoT based application.
- We use RFID tag for user identification which is EM18 RFID reader can read 12 kHz tags OD.
- This project will contain all features despite this system have user identification system which monitor garbage and beneficial for all.

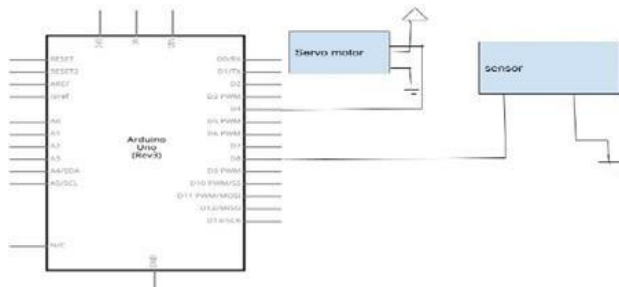

Fig. 2. Architecture model

3 Objective

There has been talk of waste disposal in many papers. In all papers, notification is sent using Wi-Fi or GSM technology. But no paper was asked to collect personal information of user. Right now we don't know who is dumping garbage and who is dumping what kind of garbage. As in our paper we will also tell you who disposed the garbage and how often waste are disposed of. [6]

In addition, whenever a user puts garbage in the dustbin, we will also provide them with some bonus points they can see in the IOT-based (Internet of Things) application, our project trash is also segmented, as well as monitoring and rewarding, which will keep the user motivated. And here we will work with the help of the RFID tag. This card will upload user data online with the help of a Wi-Fi controller. By controlling everything, we use wi-fi technology.

We think in our project we should create a dustbin that can separate all types of waste. We want to separate dry, wet, glass. We want to make a cheap and very easy to use dustbin. There are many types of rubbish; we can't take different boxes for all of them. However we will try to make such a smart dustbin itself. People are encouraged to use and use that dustbin; the user can view his trash data in the app. In our project we will collect user data using RFID technology. The user will use the RFID tag in this process. The Wi-Fi controller will handle all this activity with a separate sensor. As well as servo DC motor [6],[7].

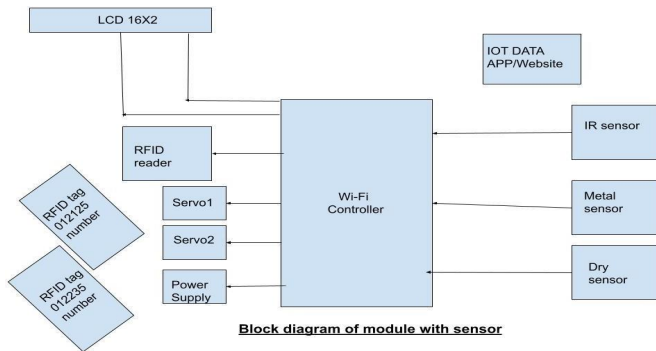

Fig. 3. Block diag of module with sensor

4 Development and Framework

In this we use different types of sensors, DC servo motor, Wi-fi controller (Node MCU), RFID tag, and IOT application. First we have to use data sensing method in this we will use different sensors like metal sensor, IR sensor, moisture sensor to sense the garbage, the sensor sends data to Wi-fi controller, It is used to send signal to DC servo motor that will separate different types of waste automatically.

To make the project unique we use RFID card to identify information of user which is EM-18 RFID module to read RFID tag data, we also use 16x2 LCD with 12C module, 12C module reduce number of wire interface. We use Node MCU controller as main controller. 12C LCD module work on serial communication protocol that will use only four wires that is SDA, SCL, 5volt and GND pins also we use servo motor that can rotate with great precision motor consist of a control circuit that provide feedback on the current position of motor shaft and feedback allow servo motor to rotate with great precision and

in the end we use EM-18 RFID module that can read 125kHz tags and gives serial output with range of 8-12cm, there's built in antenna it can be connected to PC with the help of RS232.

We want to separate dry, wet glass. We want to make a cheap and very easy to use dustbin. There are many types of rubbish; we can't take different boxes for all of them. However we will try to make such a smart dustbin itself. People are encouraged to use and use that dustbin; the user can view his trash data in the app. In our project we will collect user data using RFID technology. The user will use the RFID tag in this process. The Wi-Fi controller will handle all this activity with a separate sensor as well as a servo DC motor [8],[9].

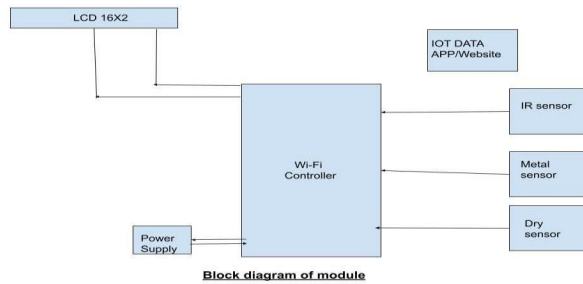

Fig. 4. block dig of module

5 System Design

The IoT garbage monitoring system is very new program that will help keep cities clean. This setting monitors Level the waste in the bins and indicate the level of waste collected Ultrasonic sensors are set to detect the drums as well. The amount of waste associated with the depth of the barrels [9].

The machine is controlled by microcontroller as well show the path to the LCD module and data transfer powered by a wi-fi module. Process enabled by 12V supply, displays a graphical view of garbage bins the sensors will respond and make effective consent. IR effect the sensor gives digital output usually "1" or "0". This has two conditions true or false [9]. The IR sensor says placed on top of a dust bin. When the IR sensor is detected the garbage level gives the impression of "1" and then goes to the true case again SMS will be sent to the relevant authorities. If IR the sensor does not sense the levels, it produces a concept "0" to get into a false case. In this case, there is no SMS sent and the process repeats until it reaches the garbage level is detected by an IR sensor [10].

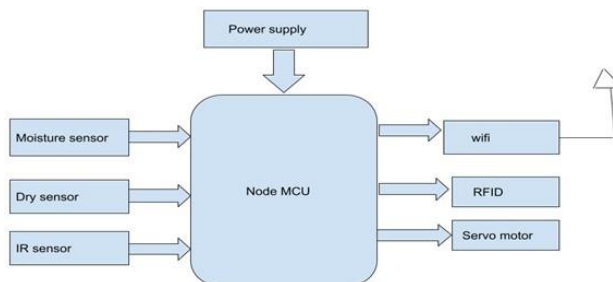

Fig. 5. System design

6 Conclusion

Garbage disposal is an important process in disposing of a plant. Next-generation plant operations are complex and expensive and cost a lot of human energy. While on the user side, a garbage monitoring and control system is required. Our proposed program meets this requirement. Our system motivates the user to use the dustbin correctly. We use a Wi-Fi controller to manage all of our project activities. Our app also has an IoT-based application that can be used by any user on his android mobile phone to compare all available solutions our system has all the features such as garbage monitoring, hearing, and garbage disposal with an additional user identification system using a simple RFID learning module. This RFID learning module and IoT app offer a lot of solution in our research.

References

- [1] V. M. Vinod and K. S. Tamilselvan, "An IoT enabled Smart Garbage Management System for Smart Cities– Indian Scenario", *Int. J. Innov. Tech. Exploring Eng.*, vol. 9, no. 4, 2020.
- [2] C. Bhangale et al., "Smart Garbage Segregation & Handling System Using IoT", *IJCRT*, vol. 8, no. 3, pp. 2780-2783, 2020.
- [3] T. Saminathan and A. Musipatla, "IoT Based Automated Waste Segregator for Efficient Recycling", *IJITEE*, vol. 8, no. 6S, 2019.
- [4] P. Babasaheb et al., "IOT Based Garbage Management System: A Review", *IJAREEIE*, vol. 8, no. 4, 2019.
- [5] R. Rajkamal et al., "A Novel Approach for Waste Segregation at Source Level for Effective Generation of Electricity GREENBIN", in *Int. Conf. on Sci. Eng. and Management Research*, 2017.
- [6] R. K. Kodali et al., "Smart Solid Waste Management", in *3rd Int. Conf. on Appl. and Theo. Compu. and Commu. Techn.*, 2017.
- [7] B. R. S. Kumar et al., "Eco-friendly IOT based waste segregation and management", in *Int. Conf. on Electrical, Electronics, Communication, Computer, and Optimization Techniques*, 2017, pp. 297-299.
- [8] N. P. Shamin et al., "Smart Garbage Segregation & Management using Internet of Things (IOT) & Machine Learning (ML)", in *1st Int. Conf. on Innovations in Information and Communication Technology*, 2019.
- [9] W. Pereira et al., "Smart Bin Waste Segregation and Optimization", *Amity Int. Conf. on Artificial Intelligence*, 2019.
- [10] P. W. Gen et al., "Two-way powered microcontroller-based plastic bottles 'drop-and-tap' reverse vending machine with stored value system using radio frequency identification (RFID) scanner technology", in *IEEE 9th Int. Conf. on Humanoid, Nanotechnology, Information Technology, Communication and Control, Environment and Management*, 2017, pp. 1-8.